

# Data Sheet

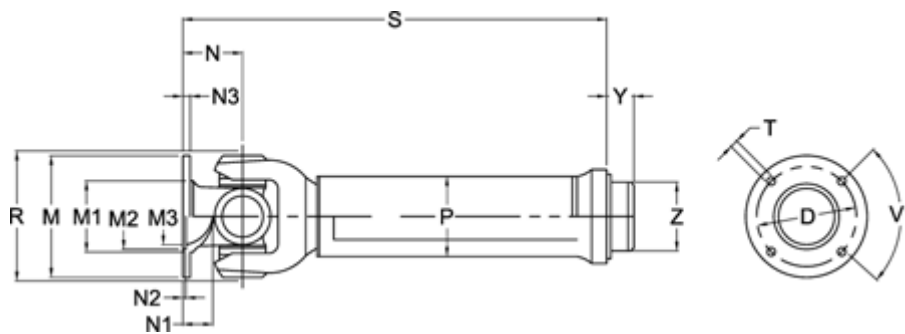

Article number: 071170700412110  
 Description: Cardan drive shaft 0.117.070.001  
 S=412 X=110 Bore with keyway

## Measures



D	= 130 $\pm$ 0,1	N1	= 29	T	= 12 B12
Extension X	= 110	N2	= 3 $\pm$ 0,5	V1 degrees	= 30
Flange diameter M	= 150	N3	= 12	Y	= 30
M1	= 104	Number og Flangeholes	= 12	Z	= 90.25
M2	= 90	P	= 100x5		
M3	= 85	R1	= 158		
Max. Bending Angle degrees	= 30	S min	= 412		
N	= 86	Spline dim. DIN 5480	= 65x2,5x24		